



**VET**

## Descrição / Características

Válvula de bloqueio de fluxo Classe 300 indicada para utilização em diversos líquidos, gases e vapores em ampla faixa de temperatura e pressão conforme norma ASME B16.34.

Construção tripartida (um corpo e duas tampas), facilitando a manutenção sem a necessidade de desconectar as extremidades da linha.

Haste à prova de expulsão.

Disponível na construção com dupla vedação, o que proporciona maior segurança quando utilizadas em linha de vapor.

Acionamento manual por alavanca com ou sem trava para cadeado ou lacre, disponível também com acionamento por atuador pneumático, elétrico ou caixa de redução.

Normas de Referência

Construção: ASME B 16.34 | ISO 17292  
API 608

Testes: API 598 | ISO 5208

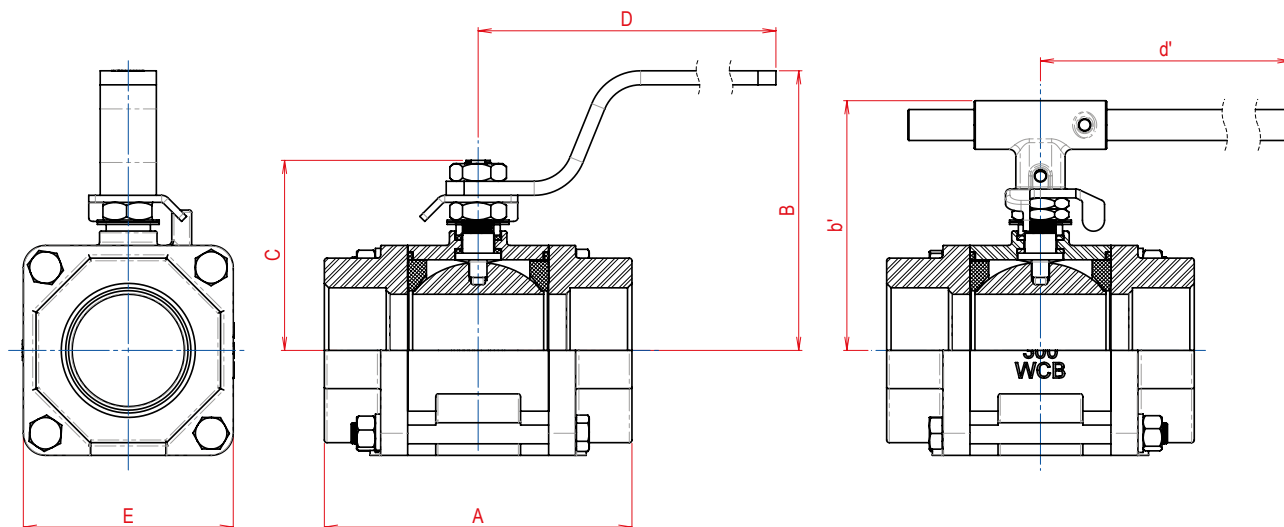

TIPOS DE CONEXÕES

ENCAIXE DE SOLDA SW

ROSCA BSP OU NPT

PONTA P/ SOLDA DE TOPO

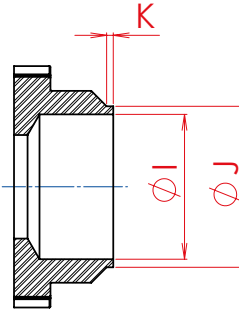
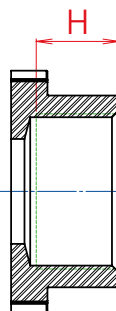
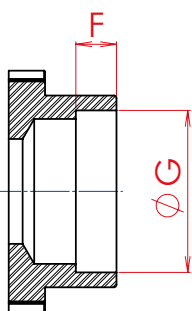

VÁLVULA DE ESFERA TRIPARTIDA PASSAGEM REDUZIDA (PR)																	
BITOLA		PASS.	A*	B	b'	C	D	d'	E	F	G	H	I	J	K	PESO kg	Coeficiente de Fluxo Kv (m³/h)
POL.	DN																
1/2"	15	11,1	62,0	46,0	73,5	39,0	125,0	225,0	43,5	9,5	21,8	17,0	15,8	21,8	2,0	0,49	5,0
3/4"	20	14,0	71,6	48,0	75,0	41,0	125,0	225,0	48,0	12,5	27,1	17,0	20,9	27,1	2,0	0,61	9,8
1"	25	20,4	88,6	82,0	87,0	51,0	165,0	225,0	57,0	12,5	33,8	23,0	26,4	33,8	2,0	1,05	18,7
1.1/4"	32	25,4	101,0	86,0	90,5	60,0	165,0	225,0	64,0	12,5	42,6	23,0	35,0	42,6	2,0	1,40	42,0
1.1/2"	40	31,7	111,7	110,0	98,5	73,0	170,0	225,0	73,0	12,5	48,7	28,0	41,0	48,7	3,0	2,20	72,0
2"	50	38,0	121,5	113,0	103,0	77,0	170,0	225,0	81,5	16,0	61,0	28,0	52,5	61,0	3,0	2,90	107,0
2.1/2"	65	50,8	138,8	125,0	112,5	86,0	256,0	225,0	94,0	16,0	73,8	28,0	62,7	73,8	3,0	4,65	185,0
3"	80	63,0	176,5	145,0	147,5	116,0	267,0	415,0	116,0	16,0	90,1	37,0	78,1	90,1	3,0	8,70	305,0

VÁLVULA DE ESFERA TRIPARTIDA PASSAGEM PLENA (PP)																	
BITOLA		PASS.	A*	B	b'	C	D	d'	E	F	G	H	I	J	K	PESO kg	Coeficiente de Fluxo Kv (m³/h)
POL.	DN																
1/4"	8	11,1	62,0	46,0	73,5	39,0	125,0	225,0	44,0	9,5	14,0	11,0	9,3	14,0	2,0	0,54	5,0
3/8"	10	11,1	62,0	46,0	75,0	39,0	125,0	225,0	44,0	9,5	17,6	11,0	12,3	17,6	2,0	0,52	5,0
1/2"	15	14,0	71,5	48,0	75,0	41,0	125,0	225,0	48,0	9,5	21,8	17,0	15,8	21,8	2,0	0,65	14,6
3/4"	20	20,4	88,6	82,0	87,0	51,0	165,0	225,0	57,0	12,5	27,1	17,0	20,9	27,1	2,0	1,13	27,8
1"	25	25,4	101,0	86,0	90,5	60,0	165,0	225,0	64,0	12,5	33,8	23,0	26,4	33,8	2,0	1,60	56,5
1.1/4"	32	31,7	111,7	110,0	98,5	73,0	170,0	225,0	73,0	12,5	42,6	23,0	35,0	42,6	2,0	2,55	104,0
1.1/2"	40	38,0	121,5	113,0	103,0	77,0	170,0	225,0	82,0	12,5	48,7	28,0	41,0	48,7	3,0	3,30	161,0
2"	50	50,8	138,8	125,0	112,5	86,0	256,0	225,0	94,0	16,0	61,0	28,0	52,5	61,0	3,0	5,20	278,0
2.1/2"	65	63,0	176,5	145,0	147,5	116,0	267,0	415,0	116,0	16,0	73,8	28,0	62,7	73,8	3,0	9,38	460,0

A vazão apresentada em Kv (m³/h) corresponde a um diferencial de pressão (Δp) de 1 bar utilizando água como fluido de teste.

\* Para conexão BW, medidas sob consulta.

[www.bermo.com.br](http://www.bermo.com.br)

Matriz  
Blumenau  
47 2123-4444  
bermo@bermo.com.br

Filiais  
Chapecó  
49 3322-2177  
bermocco@bermo.com.br

Curitiba  
41 2111-4344  
bermocwb@bermo.com.br

Joinville  
47 3435-3635  
bermojvl@bermo.com.br

Porto Alegre  
51 3464-5159  
bermopoa@bermo.com.br

Salvador  
71 3512-4488  
bermossa@bermo.com.br

São Paulo  
11 2505-1500  
bermosp@bermo.com.br