

## Project

PAE10 ball float air eliminator is designed to automatically discharge air/gas present in a liquid system.

SIZES: NPS 1/2, 3/4, 1

CONNECTIONS: Screwed (NPT/BSPT/BSP)

WEIGHT: (approx): 7.2 lbs



## Installation

Vertical installation with flow from bottom to top.

The air eliminator should be installed at all high points of a liquid system wherever air can collect. It should be installed vertically above the pipe or equipment with inlet at the bottom.

The arrow on the nameplate should be pointing vertically upwards.

## Available Spares

Valve Seat, Ball Float & Lever Assly., Gaskets

## Ordering Information

- 1) Inlet Pressure in bar (g)
- 2) Operating Temperature in °C
- 3) Air Flow in kg/hr
- 4) Size & Model
- 5) End Connections

## Limiting Conditions

PMA: Max. allowable pressure	300 psig
TMA: Max. allowable temperature	425 °F
PMO: Max. operating pressure	150, 250 & 300 psig
Cold hydro test pressure	450 psig

CAUTION DO NOT USE FOR HAZARDOUS/POISONOUS MEDIA

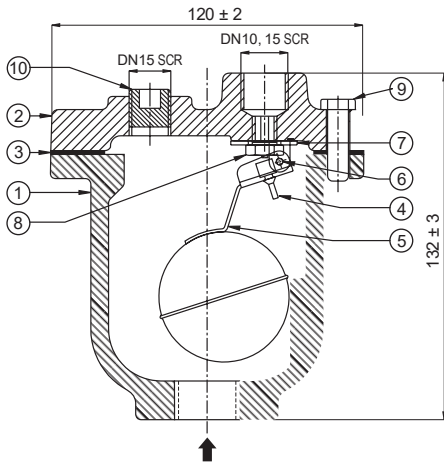

## Material

NO.	PART	MATERIAL	QTY.
1.	BODY	CAST IRON	01
2.	COVER	CAST IRON	01
3.	GASKET	NON CAF	01
4.	VALVE PIN	VITON	01
5.	FLOAT LEVER ASSY.	AISI 304	01
6.	BRACKET PIN	AISI 304	01
7.	BRACKET	AISI 304	01
8.	VALVE SEAT	AISI 304	01
9.	BOLTS	HIGH TENSILE	07
10.	PLUG	C.S.	01

## Aie Discharge Capacity AT 1PSI (AS) & 60 °F

INLET PRESS.		psi	7	15	30	45	60	75	90	100	115	125	145	150	175	225	250	290	305
m <sup>3</sup> /hr	orifice Size inches	1/16	0.85	1.16	1.74	2.3	2.9	3.5	4	4.65	5.2	5.8	6.35	6.7	-	-	-	-	-
		3/64	0.53	0.75	1.1	1.45	1.85	2.2	2.6	2.95	3.3	3.7	4.05	4.25	4.8	5.9	6.9	-	-
		1/25	0.35	0.5	0.75	1	1.3	1.5	1.8	2.05	2.3	2.55	2.8	2.96	3.35	4.1	4.8	5.4	5.6

[www.bermo.com.br](http://www.bermo.com.br)

**Matriz**  
Blumenau-SC  
47 2123-4444  
bermo@bermo.com.br

**Filiais**  
Chapécó-SC  
49 3322-2177  
bermocco@bermo.com.br

Curitiba-PR  
41 2111-4344  
bermocwb@bermo.com.br

Joinville-SC  
47 3435-3635  
bermojvl@bermo.com.br

Porto Alegre-RS  
51 3464-5159  
bermopoa@bermo.com.br

Salvador-BA  
71 3512-4488  
bermossa@bermo.com.br

São Paulo-SP  
11 2505-1500  
bermosp@bermo.com.br