

ARTICULO: 2223

Válvula de Aguja extremos roscados.

Threaded ends Needle valve.

Características

1. Válvula de Aguja.
2. Construcción en acero inoxidable:
Medidas $\leq 1"$: ASTM A479-04 (grado 316).
Medidas $\geq 1 \frac{1}{4}"$: ASTM A182 F316.
3. Extremos roscados hembra según ISO 228/1.
4. Estopada de eje en PTFE + Grafito.
5. Presión máxima de trabajo 3000 psi.
6. Rango Presión / Temperatura:
 $1/4"-1/2" = 3000 \text{ psi} / 260 \text{ }^\circ\text{C}$.
 $3/4"-1 \frac{1}{4}" = 3000 \text{ psi} / 240 \text{ }^\circ\text{C}$.
 $1 \frac{1}{2}" - 2" = 3000 \text{ psi} / 200 \text{ }^\circ\text{C}$

Features

1. Needle valve.
2. Made of Stainless steel:
Sizes $\leq 1"$: ASTM A479-04 (grade 316).
Sizes $\geq 1 \frac{1}{4}"$: ASTM A182 F316.
3. Threaded ends female according to ISO 228/1.
4. Stem Packing PTFE + Graphite.
5. Max. Working pressure 3000 psi.
6. Pressure / Temperature Range:
 $1/4"-1/2" = 3000 \text{ psi} / 260 \text{ }^\circ\text{C}$.
 $3/4"-1 \frac{1}{4}" = 3000 \text{ psi} / 240 \text{ }^\circ\text{C}$.
 $1 \frac{1}{2}" - 2" = 3000 \text{ psi} / 200 \text{ }^\circ\text{C}$

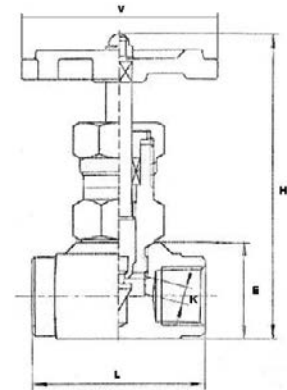
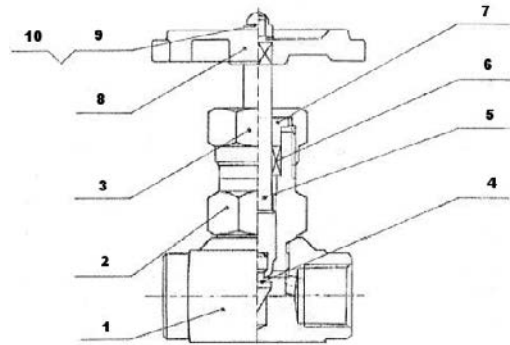

Nº	Denominación / Name	Material	Acabado Superficial / Surface Treatment
1	Cuerpo / Body	Acero Inox. / S.S. ASTM A479-04 (316) or ASTM A182 F316	-----
2	Bonete / Bonnet	AISI 316	-----
3	Tuerca prensaestopas / Nut	AISI 316	-----
4	Aguja / Needle	Inox. A182 F6 / S.S. A182 F6	Nitrurado Gaseoso / Nitrogen Treatment
5	Eje / Stem	Acero Inox. / S.S. ASTM A182 F316	-----
6	Estopada / Stem packing	PTFE + grafito / PTFE + graphite	-----
7	Prensaestopas / Packing nut	Acero Inoxidable 316 / S.S. 316	-----
8	Volante / Handwheel	Hierro fundido / Cast Iron	Pintado / Painted
9	Tuerca / Nut	Acero Inoxidable 304 / S.S. 304	-----
10	Arandela / Washer	Acero Inoxidable 304 / S.S. 304	-----

DIMENSIONES GENERALES / GENERAL DIMENSIONS

Ref.	Medida / Size	PN (psi)	Dimensiones / Dimensions (mm)					Peso / Weight (Kg)
			E	H	L	K	V	
2223 02	1/4"	3000	25	85	50	3	63	0.260
2223 03	3/8"	3000	30	100	55	4	63	0.360
2223 04	1/2"	3000	34	115	60	6	72	0.530
2223 05	3/4"	3000	40	120	70	8	72	0.760
2223 06	1"	3000	45	138	75	9	80	1.175
2223 07	1 1/4"	3000	57	165	90	11	100	1.850
2223 08	1 1/2"	3000	67	185	100	15	120	2.900
2223 09	2"	3000	78	195	120	18	140	4.700

DIAGRAMA DE PÉRDIDAS DE CARGA / HEAD LOSSES DIAGRAM

(H₂O / 20 °C Flujo Horizontal / Horizontal flow).

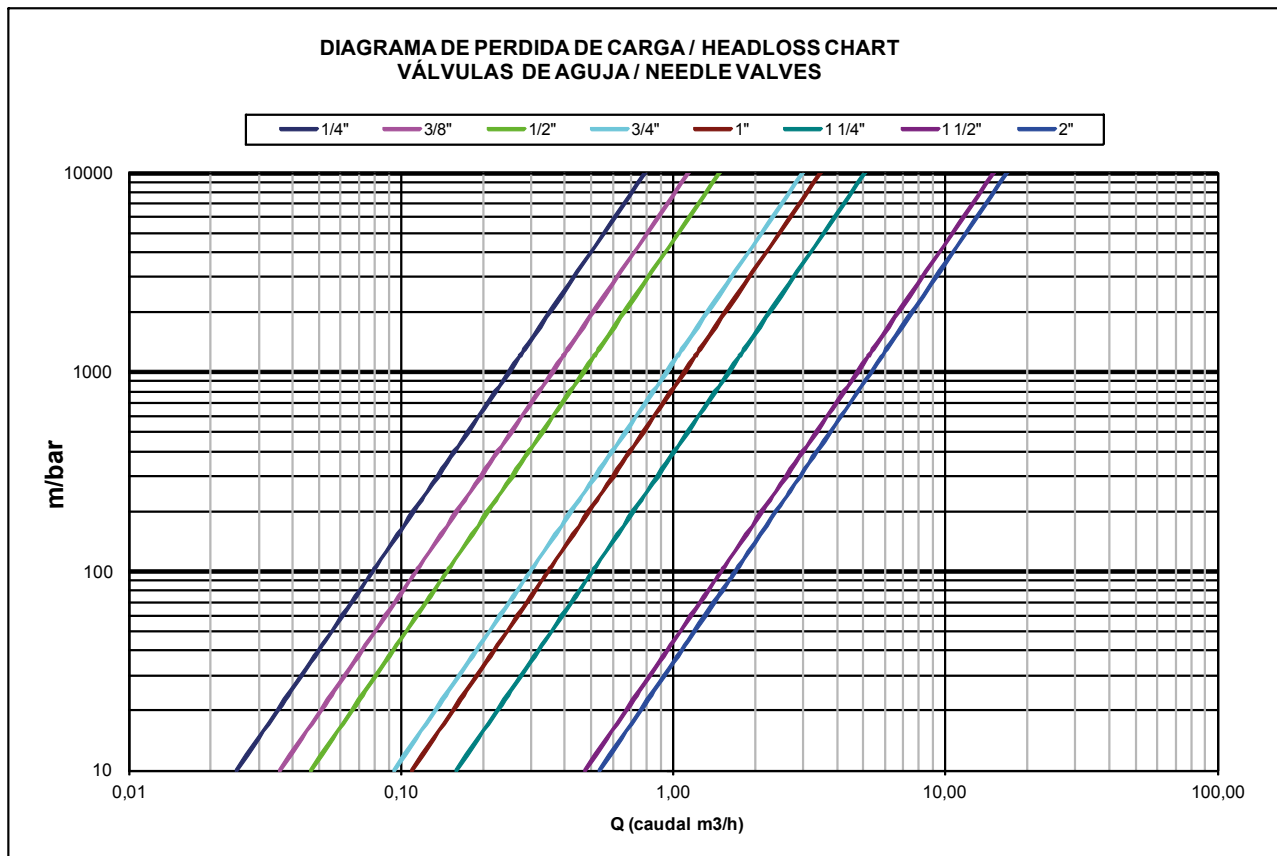

VALORES DE Kv / Kv VALUES

Kv = Es la cantidad de metros cúbicos por hora que pasará a través de la válvula generando una pérdida de carga de 1 bar.

Kv = Flow rate of water in cubic meter per hour that will generate a pressure drop of 1 bar across the valve.

Med. /Size	1/4"	3/8"	1/2"	3/4"	1"	1 1/4"	1 1/2"	2"
m ³ /h	0.25	0.36	0.47	0.95	1.1	1.6	4.76	5.36

CURVA PRESIÓN TEMPERATURA / PRESSURE TEMPERATURE RATING

